

# 86 SERIES

## Bag Filter Housing



The **86 Series** has been designed to meet the demands of most liquid processing applications where bag filters have been selected. Our novel cast head incorporates an integral one piece inlet, double vent ports and features a special bolt retaining mechanism.

The robust construction has seen these housings utilised in all areas of chemical and liquid processing. With minimal product hold up volumes and easy access to the disposable filter bag via the retained hinged lid, operators will always favour this style of housing when given a choice. Safety is also greatly improved for hazardous or high temperature fluids. The top entry, bottom outlet configuration holds almost 20% less in volume than the conventional side entry housing.

The **86 Series** filter assembly offers a cost effective and practical filtration solution for most liquid applications.



Available in 316L Stainless Steel it is suitable for operating parameters of 10 bar at 150°C with a flow capacity of up to 30m<sup>3</sup>/Hr. Two housing sizes are available for the 7" diameter bags, P1 (16") single length and P2 (32") double length. Our perforated basket retains most standard commercially available filter bags found

on the market today including steel ring, moulded polypropylene and many other types.

### Product Features

- Robust hinged closure with quick opening swingbolts
- Minimal product hold-up volume
- Excellent access to bag support basket right at the top of the housing
- Integral vent to aid efficient filter changeout
- Each housing is hydrostatically pressure tested
- Bead blasted finish inside and outside
- Robust bag support basket assembly fabricated from perforated sheet rather than wire mesh for extra strength
- Positive bag seating mechanism to minimise risk of seal bypass
- Rated at FV/10 bar g liquid, FV/10 bar g gas
- PED and ATEX Compliant



Accessories	Part Number
Pressure Gauge and Vent Valve Kit 	60S000016
Pressure Gauge and Auto Vent Valve Kit 	60S000082
Displacement Pod 	81S011000

## Features and Benefits

- Investment cast top cover and inlet flange
- Unique retained swing bolt assemblies with eye nuts
- Double vent tapping points on cover
- Wide range of options available for connection sizes and types and materials of construction
- Each housing is etched with a unique serial number for full traceability
- Full housing customisation service available

## Product Range

Amazon Filters design and manufacture an extensive range of liquid filtration systems, providing one of the widest selections of filtration vessels, depth filters and pleated cartridges available today, ensuring excellent process and filter compatibility. As one of Europe's leading manufacturers of filtration systems, Amazon Filters is able to offer a solution to meet all filtration requirements. Amazon's filters are manufactured in clean room conditions and all products come with detailed Product Validation Guides and Technical Support documentation.



# 86 Series Technical Data

## Maximum Operating Conditions

Pressure Range: Liquid: FV / 10 bar g  
Gas: FV / 10 bar g  
Temperature Range: -10°C / 150°C

## Materials of Construction

Body and Closure: 316L St. Steel  
Bolting: Carbon Steel

## Finish

Vessel: Bead blasted inside and out  
Basket: Pickled  
Swing Bolts: Zinc plated carbon steel (Optional Stainless Steel)

## Connections

Inlet/Outlet: 2" Flanged  
Vent: 1/4" BSPF with Plug

Model	Dimensions					Volume (Litres)	Dry Weight
	A	B	C	D	E		
86011UHB20C1BV	708	571	250	303	400	16.0	56.0
86012UHB20C1BV	1068	931	250	303	750	28.0	65.0

## PED Status:

Compliant with 97/23/EC  
Fluid Groups: Liquids Group 1 + 2  
Gas Group 1 + 2

Marking: CE  
Exceptions: Group 1 liquids - Explosive

## ATEX:

Compliant 94/9/EC, level CE Ex II 2 GD c X

Technical drawings for each individual housing showing dimensions, volume, weights, maximum temperatures and design pressures available on request.

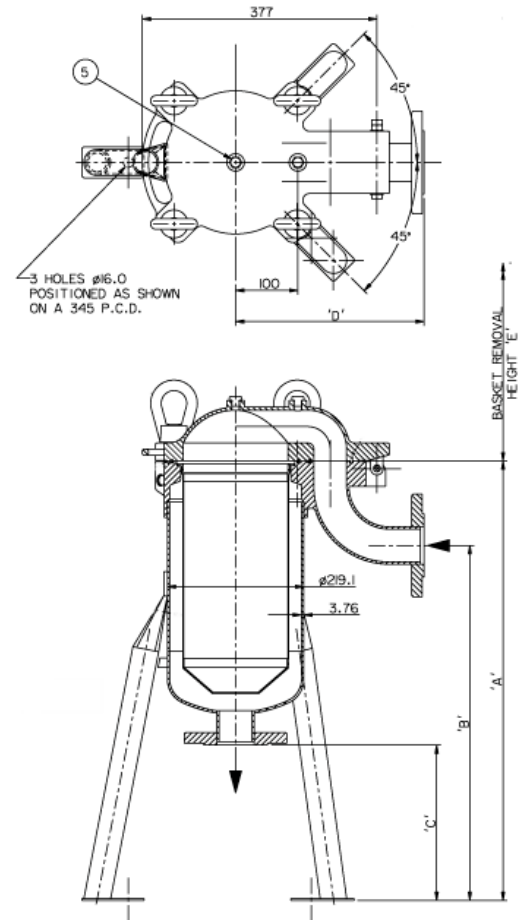

# Ordering Guide

8601	1	U	H	B	20	C	1	B	V
No of Bags	Bag Length	Bag Collar Style/Size	Bolting	Mounting	Connection	Connection Type	Materials	Finish	Seal
01 - 1 Bag	1 - Single 2 - Double	U - Universal (7") T - Universal with perforated base (7") N - No Basket	H - Zinc plated carbon steel swing bolts W - St. Steel swing bolts	B - Fixed legs C - Adjustable legs	20 - 2"	C - BS4504 Flange PN16 H - ANSI Flange 150# D - BS4504 Flange PN25* J - ANSI Flange 300#* *Type D + J increase pressure rating to 16 bar g	1 - 316 St. Steel (L Grade)	B - Bead blasted	V - Viton F - FEP / Silicone S - Silicone

Example: 86011UHB20C1BV = 86 Series, Single length bag, Universal 7" bag collar, Hinged cover with swing bolts, Mounted on Fixed Legs, 2" BS4504 Flange PN16 connections. 316L St. Steel with bead blasted finish and Viton seals.

## AMAZON FILTERS LTD.

ALBANY PARK ESTATE, FRIMLEY ROAD  
CAMBERLEY, SURREY, GU16 7PG  
ENGLAND

**Tel.** +44 (0) 1276 670600  
**Fax.** +44 (0) 1276 670101  
**Email.** sales@amazonfilters.co.uk  
**Web.** www.amazonfilters.com

## Blue H2O Filtration Pty Ltd

The Filtration Specialists

+61 (03) 9564 7029

[www.bhftechnologies.com.au](http://www.bhftechnologies.com.au)

