



VSH Multi Housings

- beverage

- Multi-element sanitary liquid housing
- Designed specifically for the food and beverage industry
- High quality crevice free construction
- Available in 3 to 30 round versions
- Steam sterilisable



Specification

Materials of Construction

- Housing: 316L Stainless Steel
- Seals: Silicone

Surface Finish

- Internal: Mechanically Polished Ra <0.8 µm
- External: Mechanically Polished

Steam Sterilisation

Refer to Parker domnick hunter for individual housing parameters.

Design Code

Housings designed in accordance with the European Council Pressure Equipment Directive (PED) 97/23/EC and the UK statutory pressure equipment regulations (PER) 1999 N° 2001.

Design Basis

ASME VIII Division 1.

Custom Design

Parker domnick hunter offers a specialist and fabrication service allowing individual customer system specifications to be met.

Note: For 12, 18, 24 and 30 Round options, please contact Parker domnick hunter for detailed technical drawings.

Working Condition PED 97/23/EC			Maximum Pressure			
Fluid Group	State	Temperature	031	032	033	034
Dangerous	Liquid	0 - 40 °C [0 - 104 °F]	10.00 barg (145.03 psig)	10.00 barg (145.03 psig)	10.00 barg (145.03 psig)	10.00 barg (145.03 psig)
Dangerous	Liquid	150 °C [302 °F]	7.50 barg (72.51 psig)	7.50 barg (72.51 psig)	7.50 barg (72.51 psig)	7.50 barg (72.51 psig)
Dangerous	Gas / Vapour	0 - 150 °C [0 - 302 °F]	6.80 barg (98.62 psig)	3.90 barg (56.56 psig)	2.80 barg (40.61 psig)	2.10 barg (30.45 psig)
Non Dangerous	Liquid	0 - 40 °C [0 - 104 °F]	10.00 barg (145.03 psig)	10.00 barg (145.03 psig)	10.00 barg (145.03 psig)	10.00 barg (145.03 psig)
Non Dangerous	Liquid	150 °C [302 °F]	7.50 barg (72.51 psig)	7.50 barg (72.51 psig)	7.50 barg (72.51 psig)	7.50 barg (72.51 psig)
Non Dangerous	Gas / Vapour	0 - 40 °C [0 - 104 °F]	10.00 barg (145.03 psig)	10.00 barg (145.03 psig)	10.00 barg (145.03 psig)	10.00 barg (145.03 psig)
Non Dangerous	Gas / Vapour	150 °C [302 °F]	7.50 barg (72.51 psig)	7.50 barg (72.51 psig)	7.50 barg (72.51 psig)	7.50 barg (72.51 psig)
Volume (litres)			7.3	12.6	17.8	23.1
Fluid Group	State	Temperature	051	052	053	054
Dangerous	Liquid	0 - 40 °C [0 - 104 °F]	10.00 barg (145.03 psig)	10.00 barg (145.03 psig)	10.00 barg (145.03 psig)	10.00 barg (145.03 psig)
Dangerous	Liquid	150 °C [302 °F]	7.50 barg (72.51 psig)	7.50 barg (72.51 psig)	7.50 barg (72.51 psig)	7.50 barg (72.51 psig)
Dangerous	Gas / Vapour	0 - 150 °C [0 - 302 °F]	4.50 barg (65.26 psig)	2.40 barg (34.80 psig)	1.70 barg (24.65 psig)	1.30 barg (18.85 psig)
Non Dangerous	Liquid	0 - 40 °C [0 - 104 °F]	10.00 barg (145.03 psig)	10.00 barg (145.03 psig)	10.00 barg (145.03 psig)	10.00 barg (145.03 psig)
Non Dangerous	Liquid	150 °C [302 °F]	7.50 barg (72.51 psig)	7.50 barg (72.51 psig)	7.50 barg (72.51 psig)	7.50 barg (72.51 psig)
Non Dangerous	Gas / Vapour	0 - 40 °C [0 - 104 °F]	10.00 barg (145.03 psig)	9.90 barg (143.58 psig)	6.80 barg (98.62 psig)	5.20 barg (75.41 psig)
Non Dangerous	Gas / Vapour	150 °C [302 °F]	7.50 barg (72.51 psig)	7.50 barg (72.51 psig)	6.80 barg (98.62 psig)	5.20 barg (75.41 psig)
Volume (litres)			11.0	20.0	29.1	38.2
Fluid Group	State	Temperature	081	082	083	084
Dangerous	Liquid	0 - 40 °C [0 - 104 °F]	10.00 barg (145.03 psig)	10.00 barg (145.03 psig)	10.00 barg (145.03 psig)	10.00 barg (145.03 psig)
Dangerous	Liquid	150 °C [302 °F]	7.50 barg (72.51 psig)	7.50 barg (72.51 psig)	7.50 barg (72.51 psig)	7.50 barg (72.51 psig)
Dangerous	Gas / Vapour	0 - 150 °C [0 - 302 °F]	2.30 barg (33.35 psig)	1.40 barg (20.30 psig)	1.00 barg (14.50 psig)	0.70 barg (10.15 psig)
Non Dangerous	Liquid	0 - 40 °C [0 - 104 °F]	10.00 barg (145.03 psig)	10.00 barg (145.03 psig)	10.00 barg (145.03 psig)	10.00 barg (145.03 psig)
Non Dangerous	Liquid	150 °C [302 °F]	7.50 barg (72.51 psig)	7.50 barg (72.51 psig)	7.50 barg (72.51 psig)	7.50 barg (72.51 psig)
Non Dangerous	Gas / Vapour	0 - 40 °C [0 - 104 °F]	9.40 barg (136.33 psig)	5.60 barg (81.22 psig)	4.00 barg (58.01 psig)	3.10 barg (44.96 psig)
Non Dangerous	Gas / Vapour	150 °C [302 °F]	7.50 barg (72.51 psig)	5.60 barg (81.22 psig)	4.00 barg (58.01 psig)	3.10 barg (44.96 psig)
Volume (litres)			21.3	35.3	49.7	63.9
PED Conformity Assessment Category			CAT I	CAT I	CAT I	CAT I

Physical Characteristics

Type	Dimensions (mm)			Typical Weight (Kg)
	'A'	'B'	'C'	
10" (250 mm)	606	840	290	27.0
20" (500 mm)	606	1060	540	30.0
30" (750 mm)	606	1310	790	33.0
40" (1000 mm)	606	1560	1040	36.0

Dimensions shown are for an 8 Round VSH, DN40 DIN2633 inlet / outlet connections. For the full range of dimensions and weights, please contact Parker domnick hunter.

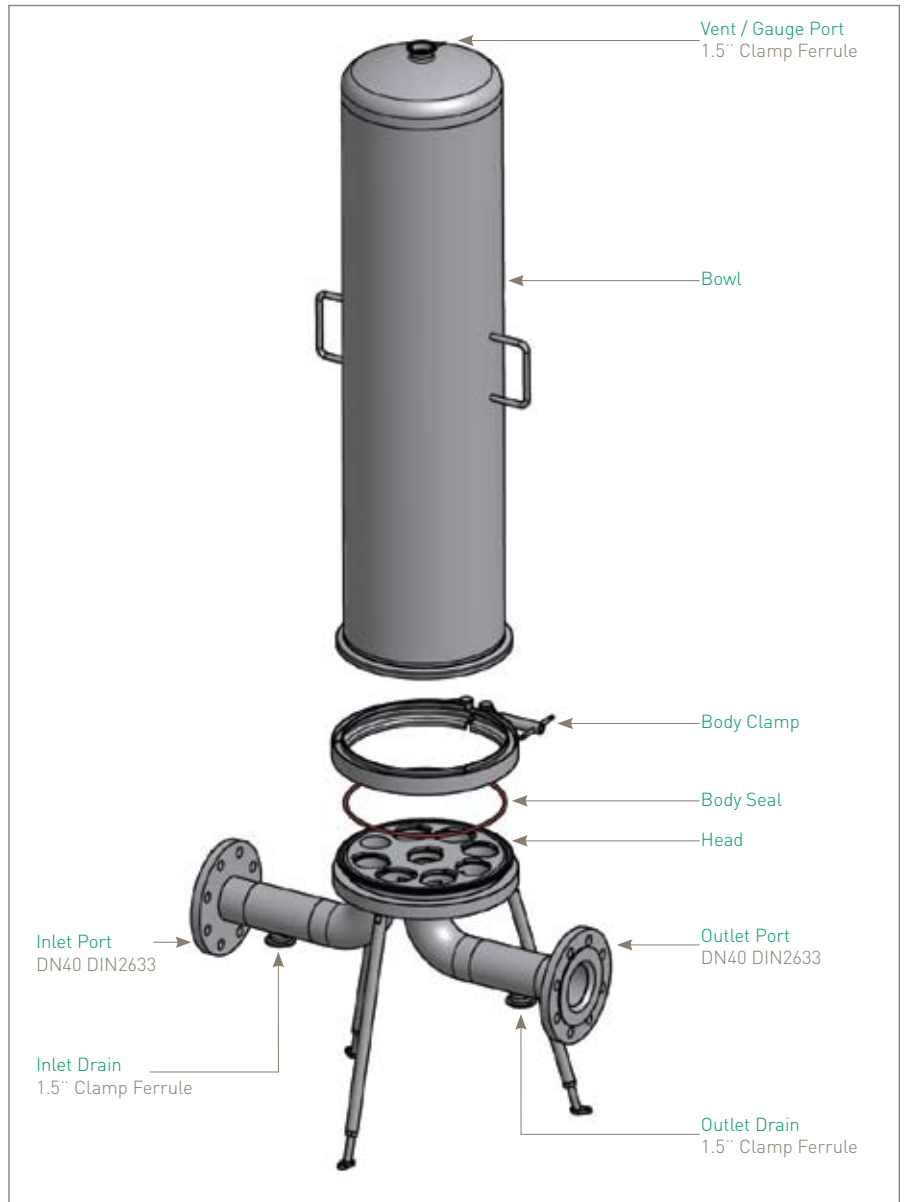
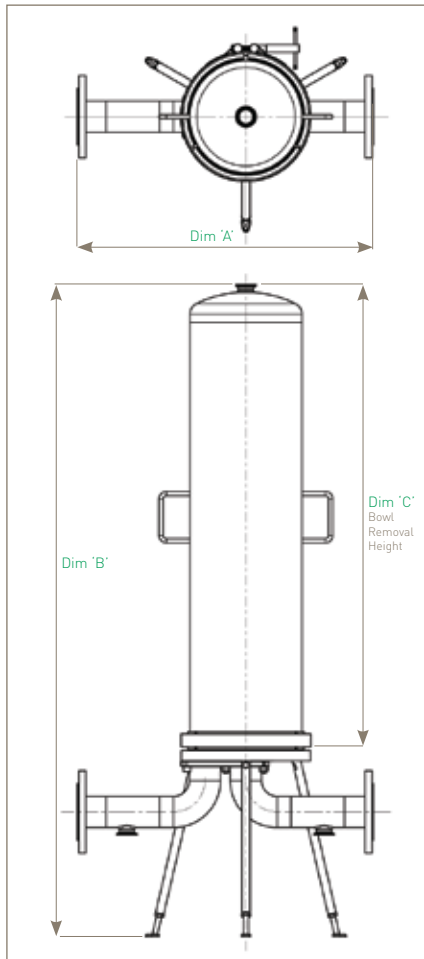

Ordering Information

VSH - - - - -

Code Vessel Class	Code N° of Cartridges	Code Length (Nominal)	Code Connection Size	Code Connection Type	Code Connection Standard	Code Vent / Drain Conn. Type	Code Seal
CE Standard	03 3 05 5 08 8 12 12 18 18 24 24 30 30	1 10" (250 mm) 2 20" (500 mm) 3 30" (750 mm) 4 40" (1000 mm)	B 1" C 1.5" & 2" X 2.5" D 3" E 4"	D DIN Male F Flanged M SMS Male R RJT Male T Tri-Clamp W Weld Prepared	A NPT / ANSI B British D DIN I ISO	T Tri-Clamp	E EPDM S Silicone V Viton

Note: 3, 5 and 8 Round housings available with 10", 20", 30" and 40" bowls
12, 18, 24 and 30 Round housings available with 20" and 30" bowls only

N° of Cartridges	Connection Size Availability			
	1.5"	2"	2.5"	3" 4"
03	✓			
05	✓	✓		
08	✓	✓	✓	
12			✓	✓
18			✓	✓
24			✓	✓
30			✓	✓

Note: For accessories, i.e. gauges, please contact Parker domnick hunter - Process Division for full availability.

Parker domnick hunter has a continuous policy of product development and although the Company reserves the right to change specifications, it attempts to keep customers informed of any alterations. This publication is for general information only and customers are requested to contact our Process Filtration Sales Department for detailed information and advice on a products suitability for specific applications. All products are sold subject to the company's Standard conditions of sale.